



OPERATOR'S MANUAL



Single Stage Snowthrower

520M Models

Mfg. No.	Description
1694585	5201M, 5HP Snowthrower, Manual Start
7085663	SS5201R, 5HP Snowthrower, Manual Start

520E Models

Mfg. No.	Description
1694586	5201E, 5HP Snowthrower, Electric Start
7085664	SS5201E, 5HP Snowthrower, Electric Start



Table of Contents

Safety Rules & Information

Training	2
Preparation	2
Operation	2
Children.....	3
Clearing a Clogged Discharge Chute	3
Service, Maintenance, and Storage	3
Emissions.....	3
Identification Numbers	4
Safety Decals	5
International Symbols	6

Assembling the Snowthrower

Controls & Operation

Snowthrower Controls.....	8
Engine & Starting Controls.....	9
General Operation	10
Checks Before Each Start-Up.....	10
Mixing Fuel.....	11
Starting the Engine	12
Stopping the Engine.....	12
Operating the Snowthrower	13
Snowthrowing Tips.....	13
After Each Use.....	13
Off-Season Storage	13
Starting After Storage	11

Regular Maintenance

Removing Belt Cover	14
Lubrication	14

Troubleshooting & Service

Troubleshooting	15
Removing Engine Cover	15
Auger Control Cable Adjustment	16
Carburetor Adjustment (Ref. only)	16
Replacing the Drive Belt	17
Replacing the Scraper Blade	17
Servicing the Spark Plug.....	17

Appendices

Specifications	18
Parts & Accessories.....	18
Technical Manuals	18

WARNING

Engine exhaust from this product contains chemicals known, in certain quantities, to cause cancer, birth defects, or other reproductive harm.

Safety Rules & Information



This machine is capable to amputating hands and feet and throwing objects. Read these safety rules and follow them closely. Failure to obey these rules could result in loss of control of unit, severe personal injury or death to you, or bystanders, or damage to property or equipment. The triangle  in text signifies important cautions or warnings which must be followed.

TRAINING

1. Read, understand, and follow all instructions on the machine and in the manuals before operating this unit. Be thoroughly familiar with the controls and the proper use of the equipment. Know how to stop the unit and disengage the controls quickly.
2. Never allow children to operate the equipment. Never allow adults to operate the equipment without proper instruction.
3. Keep the area of operation clear of all persons, particularly small children and pets.
4. Exercise caution to avoid slipping or falling especially when operating in reverse.

PREPARATION

1. Thoroughly inspect the area where the equipment is to be used and remove all doormat, sleds, boards, wires, and other foreign objects.
2. Disengage all clutches and shift into neutral before starting engine (motor).
3. Do not operate the equipment without wearing adequate winter outer garments. Wear footwear that will improve footing on slippery surfaces. Avoid loose fitting clothing that can get caught in moving parts.
4. Handle fuel with care; it is highly flammable.
 - (a) Use an approved fuel container.
 - (b) Never add fuel to a running engine or hot engine.
 - (c) Fill fuel tank outdoors with extreme care. Never fill fuel tank indoors. Replace fuel cap securely and wipe up spilled fuel.
 - (d) Never fill containers inside a vehicle or on a truck or trailer bed with a plastic liner. Always place containers on the ground, away from your vehicle, before filling.
 - (e) When practical, remove gas-powered equipment from the truck or trailer and refuel it on the ground. If this is not possible, then refuel such on a trailer with a portable container, rather than from a gasoline dispenser nozzle.
 - (f) Keep nozzle in contact with the rim of the fuel tank or container opening at all times, until refueling is complete. Do not use a nozzle lock-open device.
 - (g) Replace gasoline cap securely and wipe up spilled fuel.
 - (h) If fuel is spilled on clothing, change clothing immediately.
5. Use extension cords and receptacles as specified by the manufacturer for all units with electric drive motors or electric starting motors.
6. Adjust the collector housing height to clear gravel or crushed rock surfaces.
7. Never attempt to make any adjustments while the engine (motor) is running (except when specifically recommended by the manufacturer).
8. Let engine (motor) and machine adjust to outdoor temperatures before starting to clear snow.
9. Always wear safety glasses or eye shields during operation or while performing an adjustment or repair to protect eye from foreign objects that may be thrown from the machine.

OPERATION

1. Do not put hands or feet near or under rotating parts. Keep clear of the discharge opening at all times.
2. Exercise extreme caution when operating on or crossing gravel drives, walks, or roads. Stay alert for hidden hazards or traffic.
3. After striking a foreign object, stop the engine (motor), remove the wire from the spark plug, disconnect the cord on electric motors, thoroughly inspect the snowthrower for any damage, and repair the damage before restarting and operating the snowthrower.
4. If the unit should start to vibrate abnormally, stop the engine (motor) and check immediately for the cause. Vibration is generally a warning of trouble.
5. Stop the engine (motor) whenever you leave the operating position, before unclogging the collector/impeller housing or discharge guide, and when making any repairs, adjustments, or inspections.
6. When cleaning, repairing, or inspecting make certain the collector/impeller and all moving parts have stopped. Disconnect the spark plug wire and keep the wire away from the plug to prevent accidental starting.
7. Do not run the engine indoors except for starting the engine or for transporting the snowthrower in or out of the building. Open the outside doors; exhaust fumes are dangerous.
8. Exercise extreme caution when operating on slopes. Do not attempt to clear steep slopes.
9. Never operate the snowthrower without proper guards plates, or other safety protective devices in place and working.
10. Never direct the discharge toward people or areas where property damage can occur. Keep children and others away.
11. Do not overload the machine capacity by attempting to clear snow at too fast a rate.
12. Never operate the machine at high transport speeds on slippery surfaces. Look behind and use care when operating in reverse.
13. Disengage power to the collector/impeller when snowthrower is transported or not in use.
14. Use only attachments and accessories approved by the manufacturer of the snowthrower (such as wheel weights, counterweights, or cabs).
15. Never operate the snowthrower without good visibility or light. Always be sure of your footing, and keep a firm hold on the handles. Walk, never run.
16. Never touch a hot engine or muffler.
17. Never operate the snowthrower near glass enclosures, automobiles, window wells, drop-offs, and the like without proper adjustment of the discharge angle.
18. Never direct discharge at bystanders or allow anyone in front of the unit.
19. Never leave a running unit unattended. Always disengage the auger and traction controls, stop engine, and remove keys.
20. Do not operate the unit while under the influence of alcohol or drugs.

21. Keep in mind the operator is responsible for accidents occurring to other people or property.
22. Data indicates that operators, age 60 years and above, are involved in a large percentage of power equipment-related injuries. These operators should evaluate their ability to operate the unit safely enough to protect themselves and others from injury.
23. DO NOT wear long scarves or loose clothing that could become entangled in moving parts.
24. Snow can hide obstacles. Make sure to remove all obstacles from the area to be cleared.
8. Always follow the engine manual instructions for storage preparations before storing the unit for both short and long term periods.
9. Always follow the engine manual instructions for proper start-up procedures when returning the unit to service.
10. Maintain or replace safety and instruction labels as necessary.
11. Keep nuts and bolts tight and keep equipment in good condition.
12. Never tamper with safety devices. Check their proper operation regularly and make necessary repairs if they are not functioning properly.
13. Components are subject to wear, damage, and deterioration. Frequently check components and replace with manufacturer's recommended parts, when necessary.
14. Check control operation frequently. Adjust and service as required.
15. Use only factory authorized replacement parts when making repairs.
16. Always comply with factory specifications on all settings and adjustments.
17. Only authorized service locations should be utilized for major service and repair requirements.
18. Never attempt to make major repairs on this unit unless you have been properly trained. Improper service procedures can result in hazardous operation, equipment damage and voiding of manufacturer's warranty.
19. Check shear bolts and other bolts at frequent intervals for proper tightness to be sure the equipment is in safe working condition.

CHILDREN

Tragic accidents can occur if the operator is not alert to the presence of children. Children are often attracted to the unit and the operating activity. Never assume that children will remain where you last saw them.

1. Keep children out of the area and under the watchful care of another responsible adult.
2. Be alert and turn unit off if children enter the area.
3. Never allow children to operate the unit.
4. Use extra care when approaching blind corners, shrubs, trees, or other objects that may obscure vision.

CLEARING A CLOGGED DISCHARGE CHUTE

Hand contact with the rotating impeller inside the discharge chute is the most common cause of injury associated with snowthrowers. Never use your hand to clean out the discharge chute.

To clear the chute:

1. SHUT OFF THE ENGINE.
2. Wait 10 seconds to be sure the impeller blades have stopped rotating.
3. Always use a clean out tool, not your hands.

SERVICE, MAINTENANCE, AND STORAGE

1. Check shear bolts and other bolts at frequent intervals for proper tightness to be sure the equipment is in safe working condition.
2. Never store the machine with fuel in the fuel tank inside a building where ignition sources are present such as hot water and space heaters, or clothes dryers. Allow the engine to cool before storing in any enclosure.
3. Always refer to the operator's manual for important details if the snowthrower is to be stored for an extended period.
4. Maintain or replace safety and instruction labels as necessary.
5. Run the machine a few minutes after throwing snow to prevent freeze-up of the collector/impeller.
6. If fuel is spilled, do not attempt to start the engine but move the machine away from the area of spillage and avoid creating any source of ignition until fuel vapors have dissipated.
7. Always observe safe refueling and fuel handling practices when refueling the unit after transportation or storage.

EMISSIONS

1. Engine exhaust from this product contains chemicals known, in certain quantities, to cause cancer, birth defects, or other reproductive harm.
2. If available, look for the relevant Emissions Durability Period and Air Index information on the engine emissions label.

Product Identification

Identification Numbers

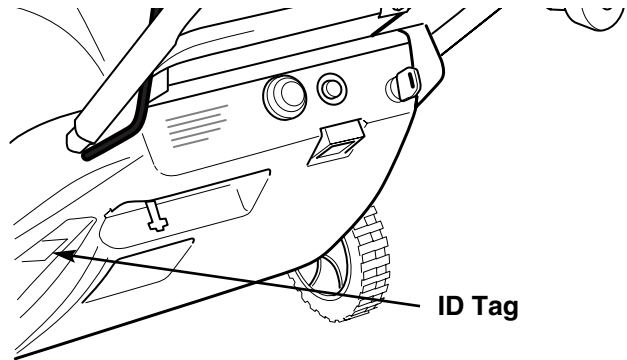

When contacting your authorized dealer for replacement parts, service, or information you MUST have these numbers.

Record your model name/number, manufacturer’s identification numbers, and engine serial numbers in the space provided for easy access. These numbers can be found in the locations shown.

NOTE: For location of engine identification numbers, refer to the engine owner’s manual.

PRODUCT REFERENCE DATA	
Model Description Name/Number	
Unit MFG Number	Unit SERIAL Number
Dealer Name	Date Purchased
ENGINE REFERENCE DATA	
Engine Make	Engine Model
Engine Type/Spec	Engine Code/Serial Number

Technical Information

Power Ratings

The power ratings for an individual engine model are initially developed by starting with SAE (Society of Automotive Engineers) code J1940 (Small Engine Power & Torque Rating Procedure) (Revision 2002–05). Given both the wide array of products on which our engines are placed, and the variety of environmental issues applicable to operating the equipment, it may be that the engine you have purchased will not develop the rated horsepower when used in a piece of power equipment (actual “on-site” power). This difference is due to a variety of factors including, but not limited to, the following: differences in altitude, temperature, barometric pressure, humidity, fuel, engine lubrication, maximum governed engine speed, individual engine to engine variability, design of the particular piece of power equipment, the manner in which the engine is operated, engine run-in to reduce friction and clean out of combustion chambers, adjustments to the valves and carburetor, and other factors. The power ratings may also be adjusted based on comparisons to other similar engines utilized in similar applications, and will therefore not necessarily match the values derived using the foregoing codes.

Safety Rules & Information

SAFETY DECALS

Safety warning decals are placed at strategic locations on the snowthrower as a constant reminder to the operator of the most important safety precautions. All warning, caution and instructional messages on your snowthrower should be carefully read and obeyed. If any of these decals are lost or damaged, replace them at once. They can be purchased from your local dealer.



Part No. 1716672
Auger Control Decal

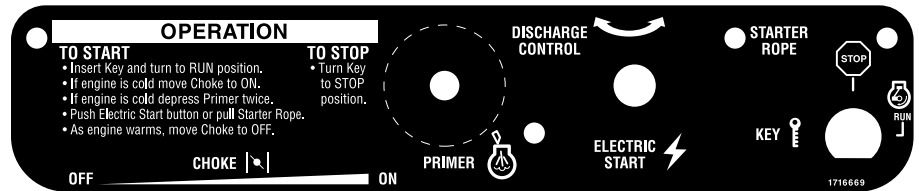

Part No. 1716669
Main Dash Decal (Electric Start Models)



Part No. 7026733
Warning Decal

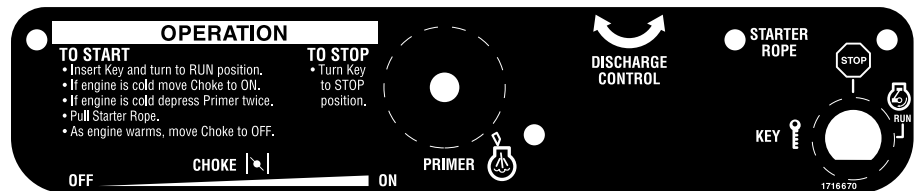

Part No. 1716670
Main Dash Decal (Manual Start Models)



Part No. 1733057
Discharge Chute Danger Decal

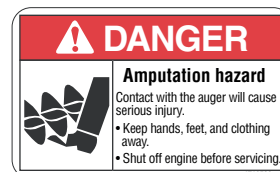

Part No. 1716532
Auger Danger Decal

Safety Rules & Information

International Symbols



FAST



CHOKE



IGNITION KEY



SLOW



PRIMER



RUN



STOP



ELECTRIC START



Assembling the Snowthrower

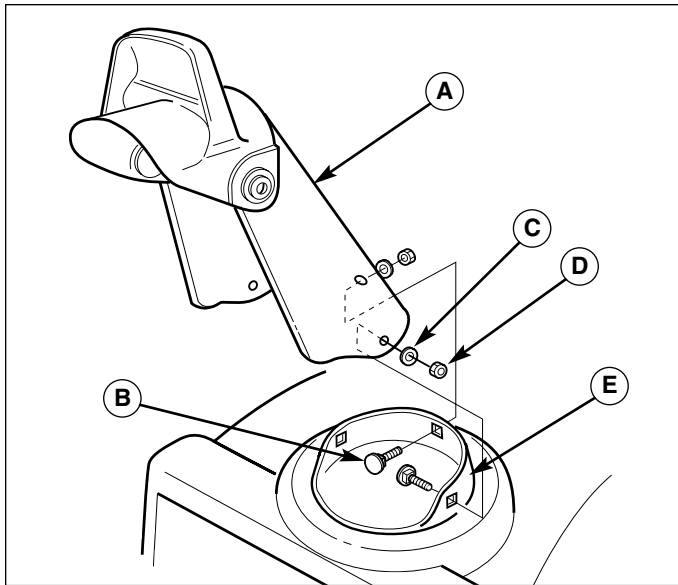

Figure 1. Assembly of Discharge Chute

- | | |
|--------------------|------------------|
| A. Discharge Chute | D. Nuts |
| B. Carriage Bolts | E. Rotating Ring |
| C. Washers | |

TOOLS REQUIRED

- Socket or Wrench Set
- Pair of Pliers

ASSEMBLY PROCEDURE

If your unit was not previously assembled, see Figures 1 and 2, and follow the steps below to assemble the unit:

1. Install the discharge chute on to the rotating ring located on the auger housing. Secure with the three 5/16 inch carriage bolts, flat washers and nylock nuts found in the parts bag (the bolt heads go to inside of the rotating ring, with washers and nuts on the outside). Note, install the rear bolt first for easier alignment.
2. Tighten bolts securely with a wrench.
3. Lift up folding handle to align it with lower handle and tighten the wing knobs securely as shown in Figure 3.
4. Insert clean-out tool into holders on left handle.



Figure 2. Handles

- | | | |
|-----------|---------------|-------------------|
| A. Handle | B. Wing Knobs | C. Clean-out Tool |
|-----------|---------------|-------------------|

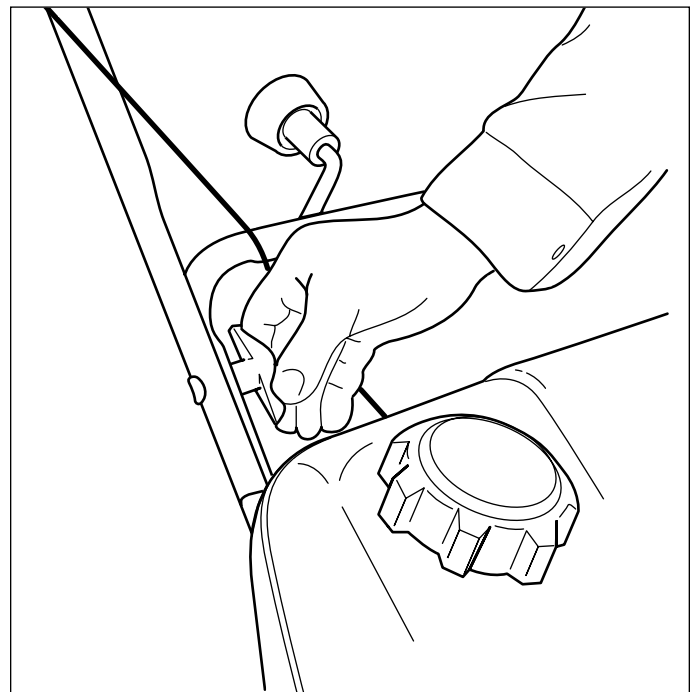

Figure 3. Lift Handles and Lock Wing Knobs

Controls & Operation



SNOWTHROWER CONTROLS

Auger Control

A. Auger Control - This control engages and disengages the auger. Pull the control back against handle to engage the auger, (this will pull snowthrower forward if auger is in contact with the ground). Release the auger control to stop rotation of auger.

Deflector Controls

B. Chute Direction Control - The chute direction control (B, Figures 4 & 5) allows the discharge chute to be rotated to throw snow in the desired direction. Snow may be thrown at any angle from straight left to straight forward, to straight right.

The length of the chute direction control can be adjusted. Remove the cotter pin (A, Figure 5) to extend or shorten the rod to desired length, then reinstall the pin.

C. Chute Deflector - Controls the distance snow is thrown. Tilting the chute deflector (C, Figure 4) UP provides a higher stream and greater distance, while tilting the deflector DOWN provides a lower stream and less distance.

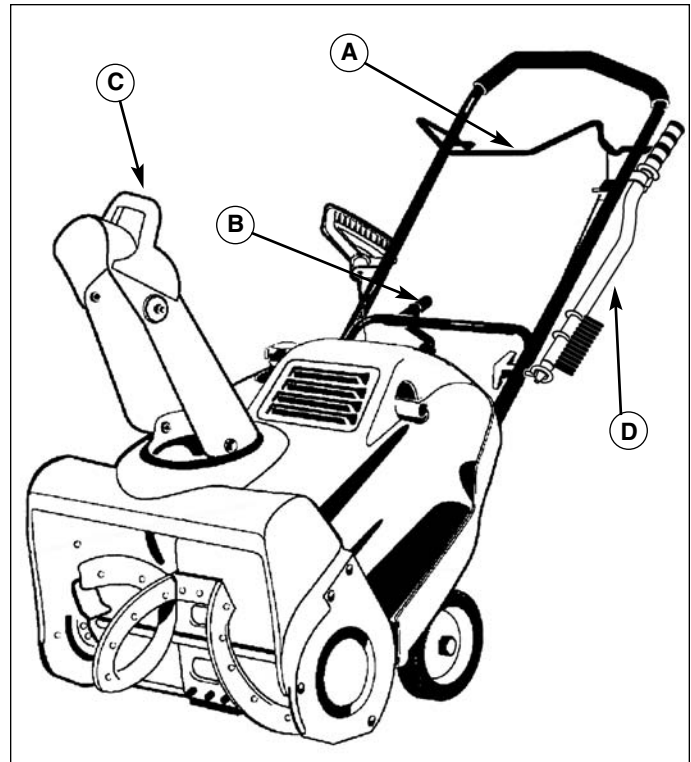

Figure 5. Snowthrower Controls

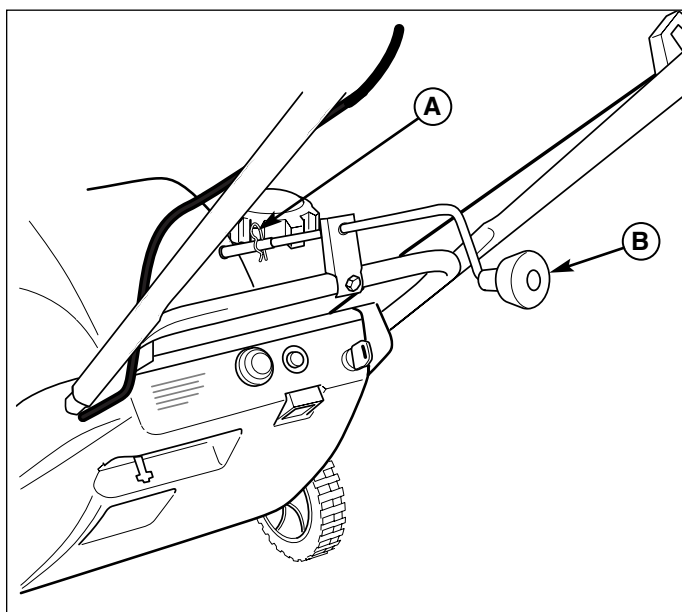

Figure 4. Discharge Chute Control Adjustment

- A. Cotter Pin
- B. Chute Direction Control

A	Auger Control	Engages auger when pulled back, and disengages auger when released.
B	Chute Direction Control	Rotates discharge chute to desired direction
C	Chute Deflector	Controls vertical angle snow is thrown.
D	Clean-Out Tool	Use to remove objects and clear the chute or auger.

Clean-Out Tool

D. Clean-Out Tool - Use to remove objects and clear the discharge chute or auger.

⚠ DANGER

DO NOT clean out discharge chute with hands. Contact with moving parts in the chute will cause serious injury. Use clean-out tool provided with machine.

ENGINE & STARTING CONTROLS

NOTE: Engine Speed Control - This snow thrower does NOT have an engine speed control. Engine speed is set at the factory. The engine governor maintains operating speed for varying snow removal conditions.

Electric Start Units Only

A. Electric Start Button - The electric start Button (A, Figure 6) activates an electric starter mounted to the engine, eliminating the need to pull the starter handle. The electric start button operates on 120 Volts AC, which is provided by connection to the extension cord provided with units equipped with this feature. **Connect this extension cord ONLY to a properly grounded 3 prong electrical outlet.**

All Models

- B. Fuel Tank Cap** - Cover fuel tank & provides venting ability to prevent vapor lock.
- C. Starter Handle** - The starter handle (C, Figure 6) connects to a starter cord to manually start the engine. Pulling starter handle rapidly spins the engine crankshaft, cycles the engine, and generates the spark necessary for starting the engine.
- D. Primer Button** - When pressed, the primer button (D, Figure 6) provides initial fuel to help start a cold engine. Normally, pressing the primer button twice will provide enough fuel to start a cold engine.
- E. Engine Key** - Insert key in switch and turn key to ON position when starting engine. To stop engine, turn key to OFF position.
- F. Choke Control** - The is control (F, Figure 6) adjusts the fuel/air mixture, and is used to help start a cold engine by providing a richer mixture. Once the engine is warm and running smoothly, the choke control should be set to the off position to provide a normal air/fuel mix.

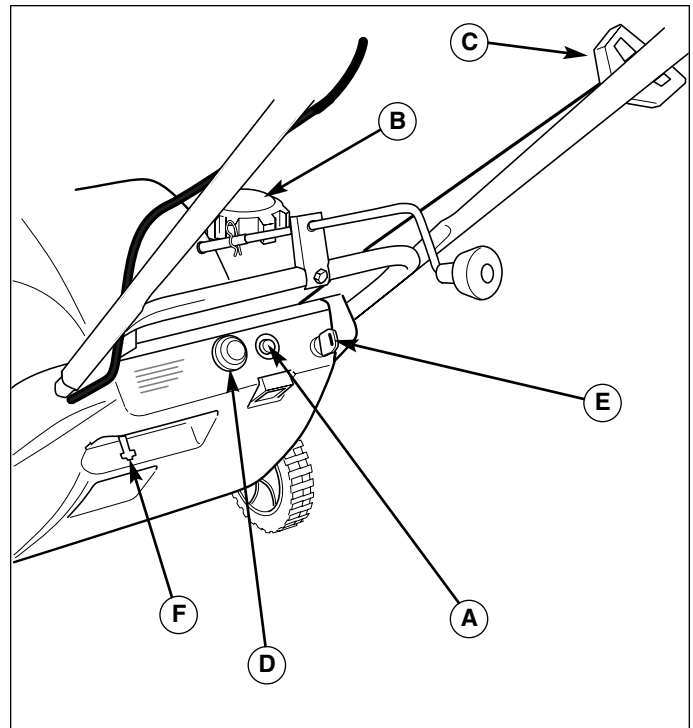

Figure 6. Engine Controls

A	Electric Start Button (Optional)	Activates electric starter
B	Fuel Tank Cap	Covers fuels tank and provides venting to prevent vapor lock
C	Starter Handle	Used to start engine
D	Primer Button	Primes carburetor for faster cold starting.
E	Engine Key	Prevents starting of engine without key. Stops engine when removed.
F	Choke Control	Adjusts air/fuel mixture

GENERAL OPERATION

CHECKS BEFORE EACH START-UP

1. Make sure all safety guards are in place and all nuts, bolts and clips are secure.
2. Check the fuel supply. Fill the tank no closer than 1/4 to 1/2 inch of top of tank to provide space for expansion. See your engine owner's manual for fuel recommendations.
3. Check the auger control (see A, Figure 4) for proper operation. If adjustment is required, see the service section (pages 13-15) for procedures.
4. Check the chute direction control (B, Figure 4) for proper operation. The discharge chute should rotate freely in both directions. See the service section for adjustment procedures and troubleshooting.
5. Check the chute deflector (C, Figure 4) for proper operation. The deflector should pivot freely up and down. See the service section for procedures.
6. Position the chute at the desired starting direction and set the deflector at the desired angle.
7. Make sure the clean-out tool is mounted in the storage position on the snow thrower.



DANGER

Never run engine indoors or in enclosed, poorly ventilated areas. Engine exhaust contains **CARBON MONOXIDE**, an **ODORLESS** and **DEADLY GAS**.



DANGER

DO NOT clean out discharge chute with hands. Contact with moving parts in the chute will cause serious injury. Use clean-out tool provided with machine.



WARNING

OPERATIONAL WARNINGS

Clearing The Discharge Chute

To avoid serious injury, do not put your hands into the auger housing or discharge chute. If the auger stalls or chute becomes plugged, use the following procedure to remove objects or clear the chute:

1. Release the auger control.
2. Shut off the engine.
3. Remove the key.
4. Wait for all moving parts to stop.
5. Use the clean-out tool to remove foreign objects and clear the chute or auger. Never put your hands into the auger or discharge chute.
6. If servicing is needed, remove cover and disconnect spark plug wire.

Discharge Chute Adjustment

Release the auger control and make sure the auger has **STOPPED** before rotating the discharge chute or adjusting the deflector. **DO NOT** place hands near the auger while the engine is running.

Thrown Objects

Objects can be thrown by the snowthrower while it is in operation. Thrown objects could cause serious injury to the operator or bystanders. Always wear safety goggles or other suitable eye protection. Keep people and pets away from the area.

Slope Operation

For your safety, operation on slopes should be in an up and down direction only. If it becomes necessary to move across the face of a slope, use caution and do not activate the auger. Be very careful when changing direction on a slope.

Proper winter footwear is recommended for the operator to help prevent slipping. Never attempt to clean snow from slopes. The maximum slope for any operation is 17.7% (10°).

Do not use the snowthrower on surfaces above ground level such as the roof of a building.

FUEL AND OIL MIXTURE

The snowthrower uses a two cycle engine that requires a mixture of fuel (gasoline) and oil for lubrication of engine bearings and other moving parts.

The correct fuel/oil mixture ratio is 50 to 1. Use fuel/oil mixture chart shown.

NOTE: To prevent damage to engine, carefully observe recommended fuel to oil mixing ratio and procedures.

- Gasoline and oil must be premixed in a clean fuel container.
- Always use fresh, unleaded, winter grade fuel.
- Never put plain, unmixed fuel into fuel tank. Shake fuel container each time before filling fuel tank.
- Never use “stale” fuel left over from last season or stored for long periods.
- **DO NOT USE MULTI VISCOSITY OILS, SUCH AS 10W-30 or 10W-40.**

PROPER FUEL MIXING PROCEDURE

1. Fill approved clean fuel container one quarter full with fresh unleaded fuel - one quart (one liter) in a one gallon (4 liter) container.
2. Pour recommended amount of **high quality two cycle oil** — 2.5 ounces (80 ml) into fuel container for one gallon (4 liters) of fuel. (**NOTE: DO NOT USE MULTI VISCOSITY OILS, SUCH AS 10W-30 or 10W-40.**)
3. Reinstall cap on the fuel container and shake container vigorously so oil mixes with gasoline.
4. Unscrew cap and fill container with fuel. Shake container again.
5. Remove fuel tank cap and carefully pour mixed fuel into the fuel tank, filling to 1/2 inch (1.5 cm) below filler neck to allow room for expansion. **Never put plain, unmixed fuel into fuel tank. Shake fuel container each time before filling fuel tank.**

WARNING

Gasoline is highly flammable and must be handled with care. Follow these fuel handling precautions:

- Use an approved fuel container.
- **DO NOT** run the unit indoors. **DO NOT** fill fuel tank indoors or while engine is running.
- Allow engine to cool for at least ten minutes before refueling.
- Wipe up any spilled fuel before starting the engine.
- Fuel vapors can travel to distant ignition sources. Keep fuel and fuel vapors away from ignition sources.

FUEL TO OIL MIXTURE CHART (50:1)

U.S.		Imperial		Metric	
Gasoline Gallons	2 Cycle Oil Ounces	Gasoline Gallons	2 Cycle Oil Ounces	Gasoline Liters	2 Cycle Oil Milliliters
1	2.5	1	2.8	4	80 ml
2	5	2	5.6	8	160 ml
5	13	5	14.1	20	400 ml

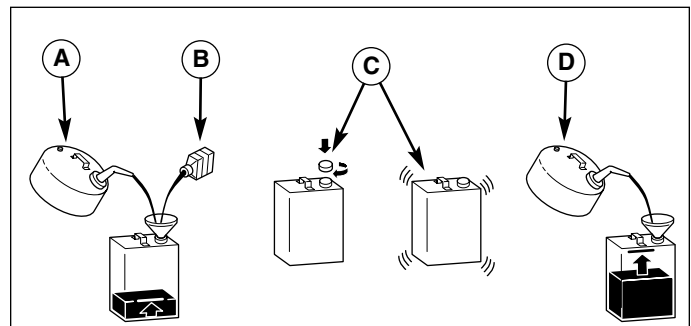

Figure 7. Proper Fuel Mixing Procedure

- A. Fill Container with 1 Quart (1 Liter) of fuel**
- B. 2.5 Ounces (80 ml) of two-cycle oil**
- C. Combine in container, then shake container**
- D. Additional fuel brings total to 1 Gallon (4 liters)**

Controls & Operation

STARTING THE ENGINE

NOTE: The snowthrower engine is designed to operate at cold temperatures. Avoid operating the snowthrower if air temperature is 40° F or warmer since engine may vapor lock and stop running after a short time. Engine will be difficult to start in warm weather.



WARNING

Electric start precautions:

- **Use only with a grounded, polarized 120V AC outlet. Do not modify the plug to fit into any other type of outlet.**
- **Use only the power cord supplied with the unit. DO NOT use a damaged cord.**
- **Be sure there is no moisture present on the cord ends or receptacles when connecting to an outlet or to the unit.**

Electric Starting Steps

Note: The electric starter is designed to operate on 120V AC household current, using power cord supplied with electric start snowthrower. When using power cord, match wide blade of plug to wide slot of receptacle.

1. Insert engine key in switch and turn key to the ON position.
2. If engine is cold, move choke control lever to the ON position. (Do not choke a warm engine).
3. Push the primer button two times if engine is cold. (Do not prime a warm engine.)
4. Plug power cord for starter into receptacle on starter switch, then plug other end into a 120Volt AC household receptacle. DO NOT use an extension cord with the electric start power cord supplied.
5. Push starter button to crank engine. DO NOT crank engine for more than a total of 15 seconds without allowing electric starter to cool for 10 minutes before additional cranking is attempted. Electric starter can be severely damaged if recommended starter operating limitations are not observed.

NOTE: Do not push primer button while engine is being cranked.

6. Release starter button when engine starts and gradually move choke lever to the OFF position.

NOTE: Always disconnect power cord from household receptacle first, then unplug from starter switch.

7. Disconnect power cord from household receptacle and then from starter switch on snowthrower. Store cord in a dry, convenient place.
8. To stop engine, turn engine key to the OFF position.

Manual (Recoil) Starting Steps

1. Insert engine key in switch and turn key to the ON position.
2. If engine is cold, move choke control lever to the ON position. (Do not choke a warm engine).
3. Push the primer button two times if engine is cold. (Do not prime a warm engine.)
4. Grasp starter rope handle and slowly pull out rope until resistance is felt. Allow rope to rewind slowly, then pull rope out rapidly to start engine. Let rope return slowly to starter.

NOTE: If engine does not start after three pulls, push primer bulb once and again pull starter rope.

5. After engine starts and gradually warms up, move choke lever to the OFF position. Be prepared to move choke lever to the ON position if engine falters during warm up.
6. Allow engine to warm up before beginning snowthrower operations. The engine will operate at full throttle when thoroughly warmed up.
7. To stop engine, turn engine key to the OFF position.



DANGER

Never run engine indoors or in enclosed, poorly ventilated areas. Engine exhaust contains CARBON MONOXIDE, an ODORLESS and DEADLY GAS.

STOPPING THE ENGINE

1. Release the auger control.
2. Turn engine key to the OFF position.
3. Remove the key from the switch if you are leaving the operating position or will be making adjustments or repairs. (NOTE: Allow the unit to cool before storing or making any adjustments or repairs.)

If you will be storing the unit for the season, see the STORAGE section for instructions on properly preparing the unit for long-term storage.

OPERATING THE SNOWTHROWER

Before operating snowthrower, review the *Checks Before Each Use* under General Operation on page 8 of this manual.

1. Rotate the discharge chute to the desired direction.
2. Pull the Auger Control back against the handle to engage the auger.

NOTE: The snowthrower will be pulled forward by the auger when the auger contacts the ground or with the snow to be thrown.

3. Begin snow removal by clearing a path down the center of walk or driveway, then gradually widen path, throwing snow off to both sides.
4. Release the auger control to stop both the auger and the forward motion of the snowthrower.

DANGER

DO NOT clean out discharge chute with hands. Contact with moving parts in the chute will cause serious injury. Use clean-out tool provided with machine.

SNOWTHROWING TIPS

Discharge chute plugging may occur as the result of snow build up inside the chute. **DO NOT** use your hands to clear the blockage, only use the clean-out tool. **DO NOT** place your hands near the auger or discharge chute any time the engine is running. Turn the engine OFF, be sure all moving parts have stopped, and clear the blockage using the clean-out tool, or put the unit indoors and allow the blockage to melt.

Varying snow conditions will affect performance of snowthrower. The snowthrower should be allowed to move into the snow at it's own pace.

Wet, heavy snow — When clearing wet, heavy snow, the forward movement of the snowthrower may have to be slowed by pushing down on handle while allowing engine to operate at full throttle.

Do not operate on **gravel or crushed rock surfaces**. Avoid picking up this type of material with auger since damage to unit could result and particles can be discharged with considerable force that could cause serious injury.

Always be alert to hidden hazards that might be struck by the auger. Should a foreign object be struck by the auger, immediately stop the engine and inspect machine for any damage. Repair damage before continuing operation.

AFTER EACH USE

Allow snow thrower to run a few minutes after clearing snow to reduce the likelihood of parts freezing while machine is not in use.

If you will be storing the unit for the season, see the STORAGE section for instructions on properly preparing the unit for long-term storage.

OFF-SEASON STORAGE

Before you store your snowthrower for the off-season, read the Service, Maintenance and Storage instructions in the Safety Rules section and take the following precautions:

NOTE: Gasoline, if permitted to stand unused for extended periods (30 days or longer), may develop gummy deposits which can adversely affect the engine carburetor and cause engine malfunction. To avoid this condition, add Dealer Line Gasoline Stabilizer to the fuel tank, or drain all fuel from the system before placing unit in storage.

NOTE: Refer to the engine manufacturer's owner's manual for engine storage information.

1. Drain fuel from the fuel tank and let the engine run until all fuel is consumed and the engine stops. Allow the unit to cool.
2. Disconnect the spark plug wire and secure away from the spark plug.
3. Tape all openings to prevent spraying water into the exhaust or air intakes.
4. Tilt the snowthrower up on its wheels and thoroughly clean the underside.
5. Lubricate all exposed metal with a light coating of oil. **DO NOT** place any type of lubrication on the drive belt or pulleys.
6. Store the unit in a shelter or other dry area protected from the weather.

STARTING AFTER STORAGE

1. Remove the spark plug and wipe dry. Then reinstall plug.
2. Fill fuel tank with fresh gasoline (unless a fuel stabilizer was used).
3. Check to be sure engine fins are clean and air flow is unobstructed.
4. Start the engine outdoors. Allow the engine to warm up before blowing snow.
5. Check the operation of all the controls.

Regular Maintenance



Removing Belt Cover

In order to perform proper lubrication, it is necessary to remove the Belt cover from the lower left of the snowthrower.

1. Remove the Engine Key from the switch.
2. Remove the four screws securing the belt cover (see Figure 8).
3. Remove the cover.
4. Perform lubrication (see below).
5. Reinstall belt cover (reverse steps 3 to 1 above.)

LUBRICATION

Note: The drive pulley end of auger shaft is supported by a sealed ball bearing and requires no lubrication. The ball bearing on other end of auger shaft is also sealed, and will not require lubrication.

Lightly Oil

- A few drops of oil should be placed on wheel hubs occasionally to keep wheels turning freely. (Note: Carefully pry off hub caps with a flat-bladed screwdriver to access wheel hubs.)
- Apply oil to pivot points of auger control periodically, wiping off any excess oil.
- A couple of drops of light machine oil applied to upper end of auger control cable will assure free movement of cable through outside casing. Wipe off any excess oil.
- Remove belt cover and lightly apply oil to the pivot point for idler pulley arm. **BE CAREFUL NOT TO GET OIL ON BELT OR PULLEYS.**



Grease

- At the beginning of each snow throwing season, remove discharge chute and generously lubricate steel flange at back of rotating ring with light grease. Rotate ring with crank to distribute grease.



Engine Lubrication

The two cycle engine used in this snowthrower is lubricated by the fuel and oil mixture. Observe recommended fuel to oil mixture ratio shown on page 9.

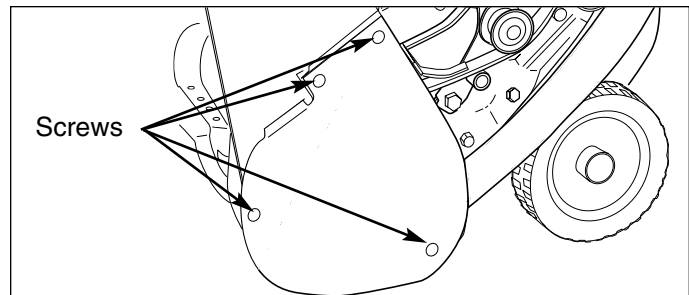

Figure 8. Removing Belt Cover

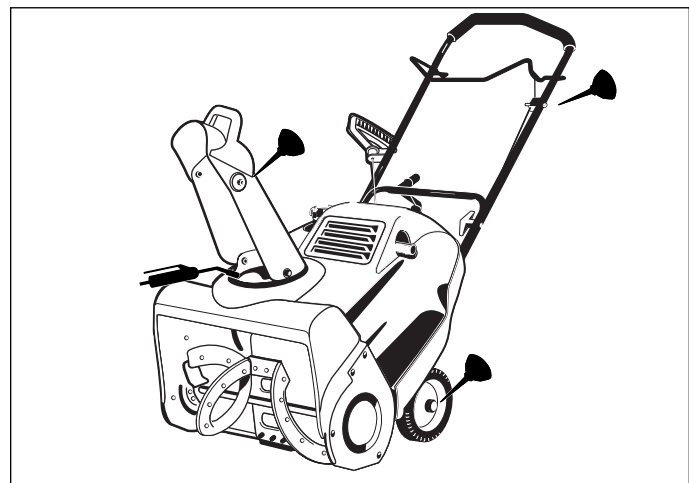

Figure 9. Lubrication points

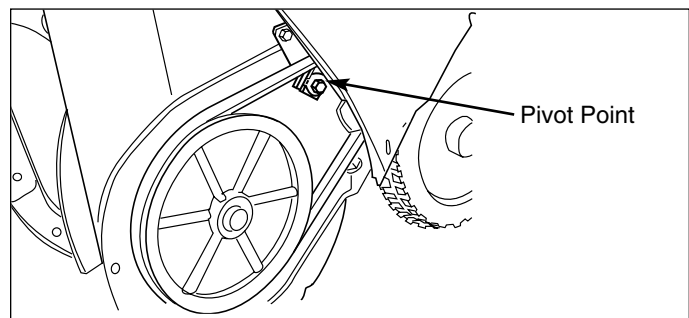

Figure 10. Lightly oil pivot point

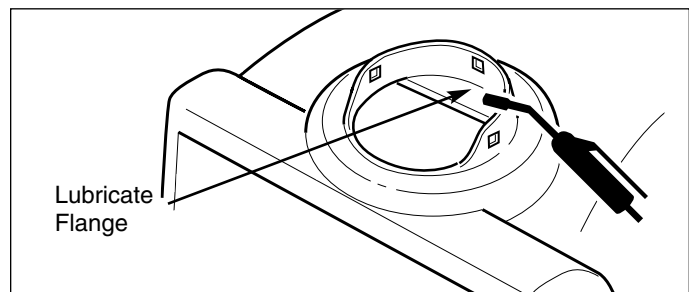

Figure 11. Grease the Discharge Chute Ring



Troubleshooting & Service

TROUBLESHOOTING

Problem	Possible Cause	Remedy
Engine fails to start	<ol style="list-style-type: none"> 1. Key is OFF 2. Failure to prime cold engine 3. Out of fuel 4. Choke OFF - cold engine 5. Engine flooded 6. Spark Plug not sparking 7. Water in fuel, or old fuel 	<ol style="list-style-type: none"> 1. Turn Key to the ON position 2. Press primer button twice and restart. 3. Fill fuel tank 4. Turn Choke to ON. 5. Turn Choke to OFF; try starting 6. Check Gap. Gap plug, clean electrode, or replace as necessary 7. Drain tank (Dispose of fuel at an authorized waste facility). Fill with fresh fuel mixture.
Engine starts hard or runs poorly	<ol style="list-style-type: none"> 1. Fuel mixture too rich 2. Spark plug faulty, fouled, or gapped incorrectly 3. Water in fuel, or old fuel 4. Gas cap vent hole plugged 	<ol style="list-style-type: none"> 1. Move choke to OFF position 2. Clean and gap, or replace 3. Drain tank (Dispose of fuel at an authorized waste facility). Fill with fresh fuel mixture. 4. Clean vent hole or replace cap
Unit does not throw snow	<ol style="list-style-type: none"> 1. Loose or broken drive belt 2. Incorrect control cable adjustment 3. Discharge chute clogged, foreign object lodged in auger 4. Broken control cable 	<ol style="list-style-type: none"> 1. Adjust or replace belt 2. Adjust Auger Control cable 3. Stop engine, remove key and clean out discharge chute 4. Replace cable
Auger does not stop turning when control is released	<ol style="list-style-type: none"> 1. Incorrect control cable adjustment 	<ol style="list-style-type: none"> 1. Adjust Auger Control cable
Excessive vibration	<ol style="list-style-type: none"> 1. Loose parts or damaged auger 	<ol style="list-style-type: none"> 1. STOP engine and REMOVE the key, tighten all hardware. If vibration continues, see your dealer.

Note: For repairs beyond the minor adjustments listed above, please contact your local authorized dealer.

REMOVING ENGINE COVER

Note: In many of the following adjustment and service tasks, it will be necessary to remove and reinstall the engine cover. To remove the cover, proceed as follows:

1. Remove the engine key from the switch.
2. Remove the two rear fasteners securing the back of the cover housing. (Figure 12).
3. Remove the fuel tank cap.
4. Remove the cover (see Figure 13 on page 14).
5. Temporarily reinstall the fuel tank cap.
6. Perform the adjustments or service desired.
7. Reinstall the cover by reversing the removal steps.

Note: The tabs at the lower front of the cover must be positioned correctly.

WARNING

Before beginning any repair stop the engine, remove the key, disconnect the spark plug wire, and wait for all moving parts to stop.

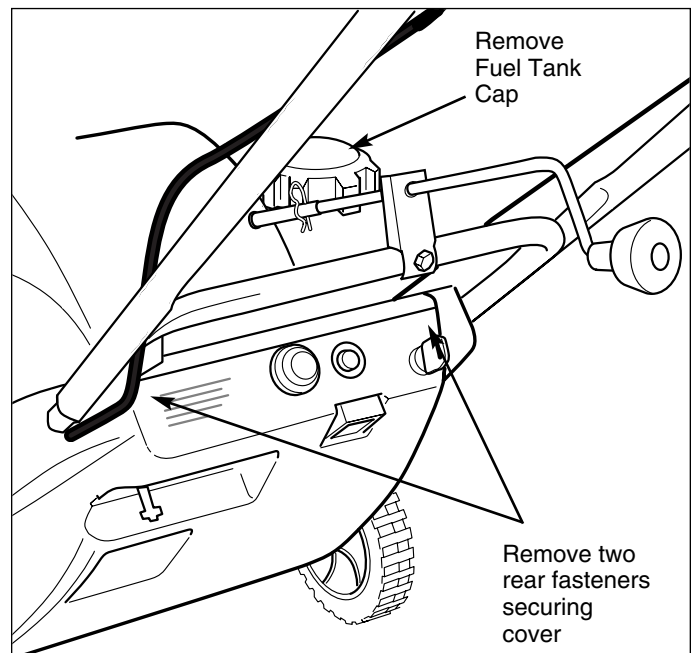

Figure 12. Remove and/or Loosen Cover Screws

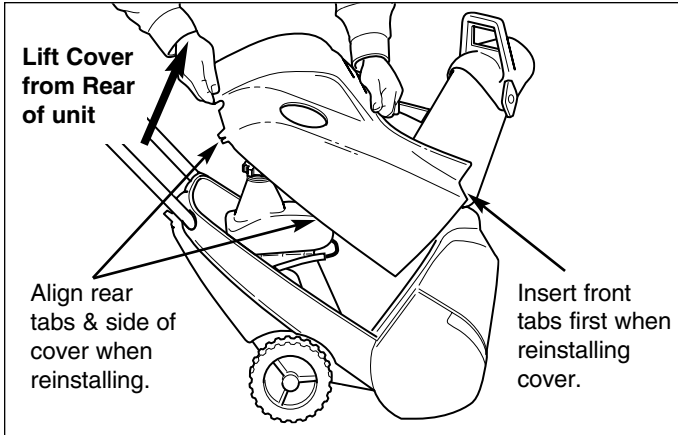

Figure 13. Cover Removal & Installation

AUGER CONTROL CABLE ADJUSTMENT

The length of the auger control cable is adjustable. However, it will seldom be necessary to change the cable length since the operating tension on the drive belt is maintained by the spring on the end of the cable.

*If the auger turns too slowly under heavy load or momentary squealing of drive belt is heard when entering heavy snow, pressure applied to drive belt by idler pulley must be increased by **reducing** the slack in the cable.*

*If the auger continues to turn when the auger control is released, the cable is too tight. The pressure applied to the drive belt must be eliminated by **increasing** the amount of slack to the cable adjustment.*

WARNING

Make certain the cable is not placing and tension on the spring. If the cable places tension on the spring, the auger may turn when the control has not been engaged.

Checking the Adjustment.

1. Remove the cover. (See page 14.)
2. Measure the spring while the auger control on the handle is disengaged. Record this measurement.
3. Pull the auger control against the handle and again measure the spring. Record this measurement.
4. Compare the two measurements. The measurement obtained with the spring extended should be 7/16 inch (11 mm) greater than with the spring at rest.

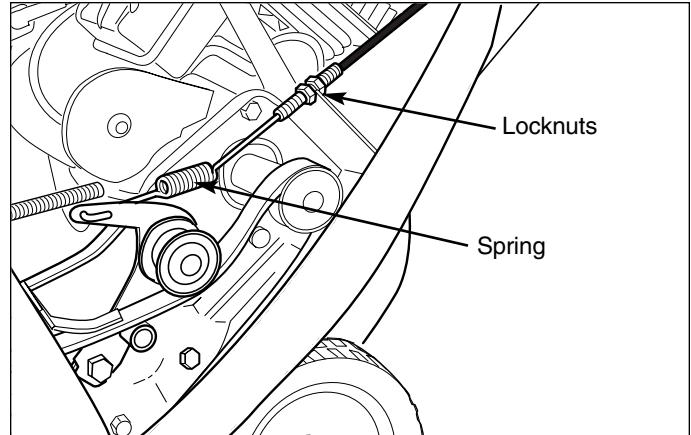

Figure 14. Auger Control Cable

Adjusting the Cable

1. Remove the engine cover.
2. Locate and loosen the lower locknut securing the auger control cable (shown in Figure 14).
3. To **change** the slack in the cable, turn the upper locknut slightly **just until the slack between the spring and the exposed cable has been eliminated**.
4. Tighten the lower locknut.
5. Test the units to make certain that the cable has been adjusted properly.

WARNING

Use extreme care when making adjustments that require engine to be running. Keep hands, feet, hair and loose fitting clothing away from moving parts.

Testing the Auger Control Cable

Start the snowthrower engine and pull back on auger control to operate auger. Release auger control and check to be sure auger stops turning.

If auger continues to turn after auger control is released, cable is too tight and will have to be adjusted to make it longer. Cable must be slightly slack when auger control is released (away from handle).

CARBURETOR ADJUSTMENT

The carburetor is properly calibrated and preset at the factory for efficient cold weather operation. There are no adjustments.

REPLACING THE DRIVE BELT

1. Remove engine key from switch.
2. Remove belt and engine covers.
3. Move the auger control on the handle and slip the belt out from between the brake lever and roller and away from the idler pulley.
4. Remove the belt from the engine and auger pulleys.
5. Install new belt around engine and auger pulleys and under idler pulley. *The ribbed side of the belt must be to the inside, against auger and engine pulleys.*
6. Slip the new belt into place between brake lever and roller.
7. Start the engine and engage/disengage the auger control several times. Make certain that auger stops turning within 5 seconds after the control is released.
8. If the auger does not stop turning within 5 second after the control is released, adjust the tension on the control cable by following the Adjusting Control Cable procedure in the Adjustments section of this manual.
9. Reinstall the belt and engine covers.

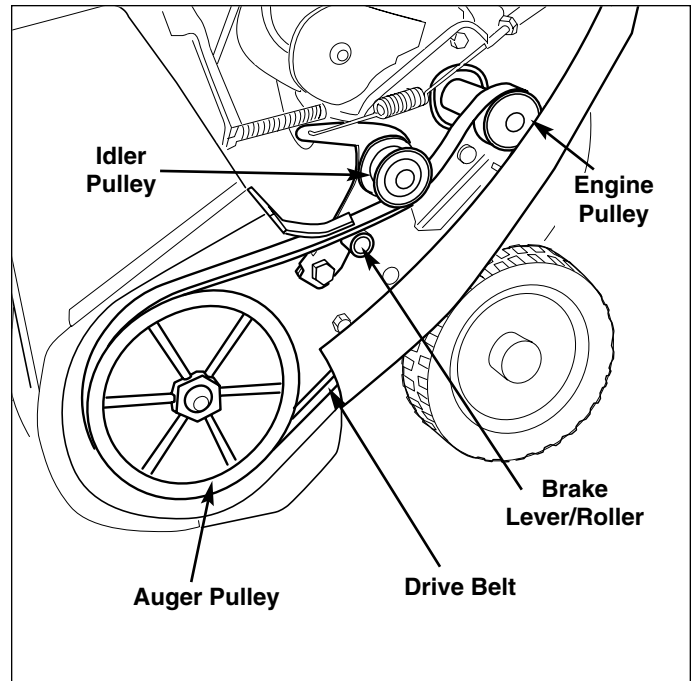

Figure 15. Drive Belt Replacement

REPLACING THE SCRAPER BLADE

1. Remove engine key from switch.
2. Remove the two bolts and nuts securing the scraper blade to the auger housing. (Retain the bolts and nuts for attaching the new blade.)
3. Remove the worn scraper blade.
4. Install the new scraper blade and secure it with the three bolts and nuts saved in step 2 above.

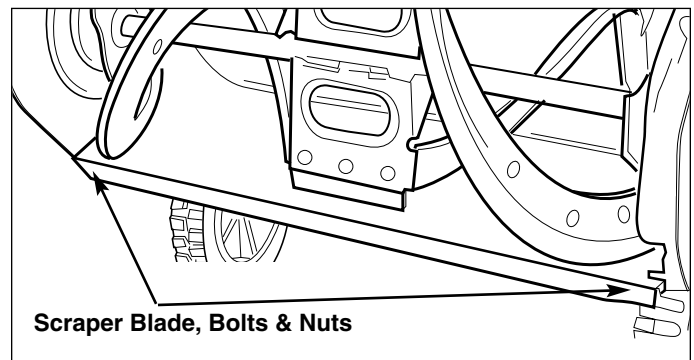

Figure 16. Removing Scraper Blade

SERVICING THE SPARK PLUG

1. Remove engine key from switch.
2. Remove the engine cover. (See page 13.)
3. Disconnect the wire from the spark plug.
4. Inspect the spark plug and clean. If necessary, replace the it with a new spark plug as recommended in the engine owners manual.
5. Adjust the gap on the spark plug to .030 inches (.762 mm) using a gauge.
6. Reinstall the plug and tighten firmly.
7. Reconnect spark plug wire.
8. Reinstall engine cover.

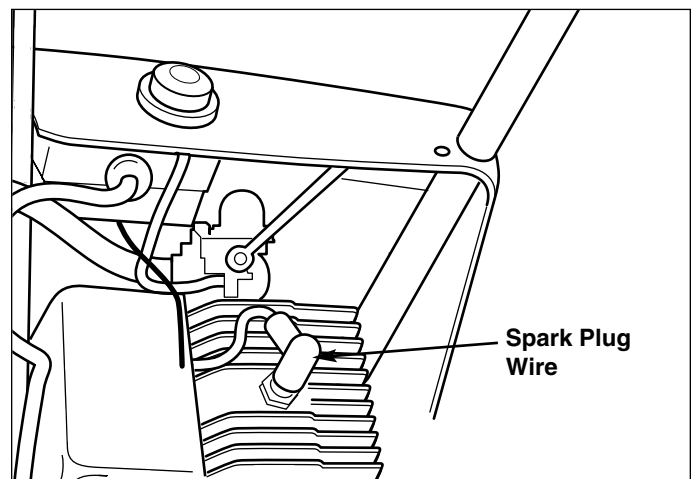

Figure 17. Servicing Spark Plug

Specifications

NOTE: Specifications are correct at time of printing and are subject to change without notice.

** Actual sustained equipment horsepower will likely be lower due to operating limitations and environmental factors. See POWER RATINGS on Page 4 for further information.*

ENGINE:

5 HP* Tecumseh

Make	Tecumseh
Model	HSK 850
Horsepower*	5 @ 4000 rpm
Displacement	8.46 Cu. in (139 cc)
Oil Mixture	50:1

CHASSIS:

Spout Rotation	220 Depress
Auger Diameter	9" (22.9cm)
Tire Size	7" x 1.5" (17.8cm x 3.8cm)

DIMENSIONS

Effective Clearing Width	20" (51cm)
Length	42" (107cm)
Height	42" (107cm)
Weight	75 lbs (34kg)

Parts & Accessories

REPLACEMENT PARTS

Replacement parts are available from your authorized dealer. Always use genuine Simplicity/Snapper Service Parts.

MAINTENANCE ITEMS

Many convenient and helpful service and maintenance items are available from you authorized dealer. Some of these items include:

Engine Oil	Tire Sealant
Touch-Up Paint	Degreaser/Degreaser
Grease Gun Kit	Gas Stabilizer
8 oz. Grease Tube	

TECHNICAL MANUALS

Additional copies of this manual are available, as well as fully illustrated parts lists. These manuals show all of the product's components in exploded views (3D illustrations which show the relationship of parts and how they go together) as well as part numbers and quantities used. Important assembly notes and torque values are also included.

For applicable manuals currently available for your Simplicity model, contact Customer Publications Department at 262-284-8519 and for your Snapper model contact 866-313-6682. Have the information listed in the box below available when phoning in your request. Technical manuals can be downloaded from www.simplicitymfg.com or www.snapper.com.

Model: _____
Mfg. No.: _____
Your Name: _____
Address: _____
City, State, Zip: _____
Visa/Mastercard No.: _____
Card Expiration Date: _____

Simplicity

MANUFACTURING, INC.
500 N Spring Street / PO Box 997
Port Washington, WI 53074-0997

www.simplicitymfg.com

© Copyright 2006, Simplicity Manufacturing, Inc.
All Rights Reserved. Printed in USA.



PRODUCTS, INC.
McDonough, GA., 30253

www.snapper.com